

PID based Dynamometer used in engine test

Pradnya Kulkarni, Chandrakant Kadu

Abstract - In today's modern world, IC engines are tested for its performances such as speed & torque developed. To test the performance of these engines dynamometer controllers & associated instrumentation is used. This paper describes how PID controller for dynamometer provides a mean for testing engine in desired & controlled conditions such as speed, torque with respect to throttle position in order to test engine. PID acts as dynamometer controller. For implementing this controller different test scenario can be simulated in lab for performing engine test with help of eddy current dynamometer. This paper presents the implementation aspects of PID in DDC using Labview and engine performance analysis in GUI(Graphical user interface).The simulation results revealed that the engine process is best tuned using Z-N technique through Labview. Finally, results extracted from simulation are displayed in GUI of test engine.

Index Terms - PID controller in DDC, Eddy current Dynamometer, Engine Behavior, controller tuning, simulation study in labview.

1 INTRODUCTION

This paper basically is about designing a LABVIEW based PID controller in DDC which acts as controller for dynamometer to control speed, torque & throttle position of IC engine. Majority of the controller used in industry are of the PI, PID type. The choice of PID controller is due to their simplicity of operation, ease of design, inexpensive maintenance, low cost, and effectiveness for most linear systems [3]. The popularity of PID controllers can be attributed partly to their robust performance in wide range of operating conditions & partly to their functional simplicity. To test engine performance in the laboratory, the engine is coupled to a dynamometer, which may be either an engine (eddy current dynamometer) dynamometer or a chassis dynamometer [2]. In this paper Eddy current dynamometers are used to measure speed & torque. One of the most essential role of the control engineer is tuning of controller [9]. This paper also presents a simulation study on PID controller tuning for engine process using well-known Z-N method through labview. Using Z-N method, it is aim to tune the PID controller parameters to achieve best control performance with the proper choice of tuning constants & finally implement PID in DDC while response of PID seen in GUI. Z-N method is the conventional tuning method in which the controller parameters are calculated from an identified process model obtained from a step response, Therefore the performance of the calculated controller parameters depends on the correctness of the identified process model developed from engine behavior [1].

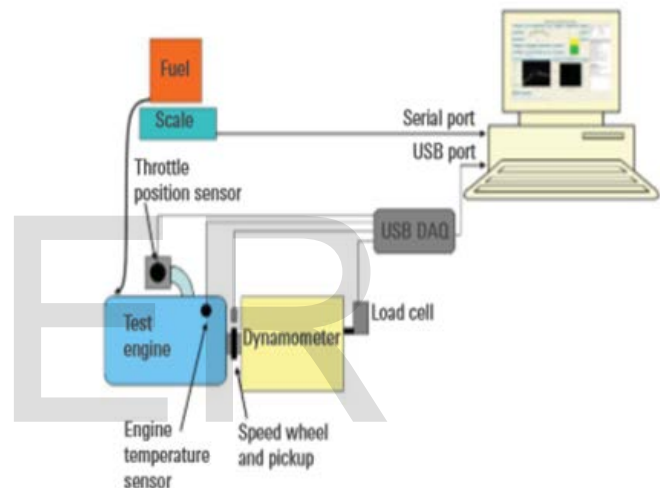

Fig 1: System Overview

2 SYSTEM OVERVIEW

Testing of engine performance is often important in the development of engine and fuel technologies. Many parameters affect an engine's performance: the basic engine design, compression ratio, valve timing, ignition timing, fuel, speed, torque & power. Proper tuning of an engine's carburetor requires careful measurements of torque, speed, temperature, and fuel consumption as a function of throttle position. Agilent USB data acquisition (DAQ) modules provide an inexpensive, flexible solution for engine testing [2]. In this study, measurement of speed, torque as function of throttle position is required. In above system overview fig 1[2] testing of engine performance in the laboratory shows that the engine under test is coupled to a dynamometer, which is eddy current dynamometer [2]. The dynamometer, which provides a load to the engine, can be easily controlled to allow testing under a wide range of speeds and torque. If load increases engine speed decreases & torque increases because load cell is kept inside dynamometer. In fig 1, three sensors are used such as throttle position sensor, magnetic pick up tachometer as speed sensor, load cell for torque measurement, While PID based

- Pradnya Kulkarni is currently pursuing masters degree program in process instrumentation in Pravara rural college of engineering, loni, Ahmednagar, Maharashtra, India.
E-mail: pskulkarni19@gmail.com
- Chandrakant Kadu is working as an Associate Professor and Head of Instrumentation & control department in Pravara rural Engineering college, Loni, Ahmednagar, Maharashtra, India,
E-mail: chandrakant_kadu@yahoo.com

dynamometer is implemented in PC for simulation purpose in which speed & torque are controlling parameter of engine under test.

2.1 Eddy Current Dynamometer

Eddy current dynamometers are electromagnetic load devices for engine testing this dynamometer is used for speed & torque measurement. The engine being tested spins a disk in the dynamometer. Electrical current passes through coils surrounding the disk, and induce a magnetic resistance to the motion of the disk. Varying the current varies the load on the engine. Several components are typically packaged together in a dynamometer: the shaft with bearings, the resistance surface, the resistance mechanism in a "free" rotating housing, a strain gage, and a speed sensor (see figure 2 for a schematic of an Eddy Current Dynamometer)[4]. Speed is measured with a pickup that monitors the spinning dynamometer. Typically, a toothed steel wheel is placed on the shaft and an inductive pickup is placed close enough to the wheel such that it generates pulses as the teeth pass by. This time-based pulse signal is analyzed in order to measure the period between pulses and converted to frequency. Shaft speed is directly proportional to the measured frequency. If the engine output is taken directly from the crankshaft, then the dynamometer shaft speed equals the engine speed [2].

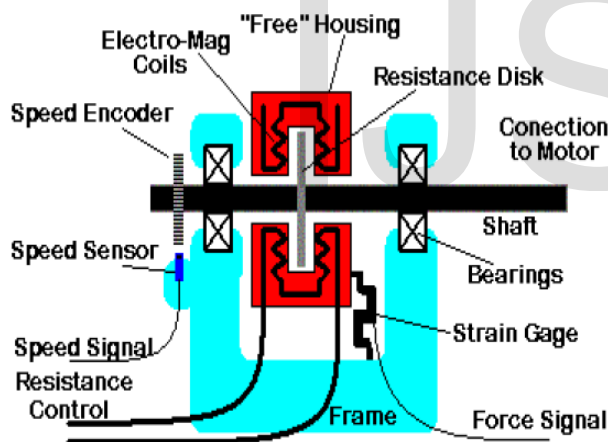

Fig 2 : Eddy Current Dynamometer

While Torque is measured by attaching a load cell (force transducer) to the dynamometer housing. The load cell strains slightly with applied load, and the strain is measured using strain gages connected to a preamplifier that outputs a voltage proportional to the load[2]. The force signal (F) from the strain gage may be converted into a torque (T) by multiplying by the distance from the center of the shaft to the pivot point of the strain gage (R):

Torque measurement by dynamometer is given by equation (1)[2]:

$$T = R \times F \quad (1)$$

2.2 Digital Dynamometer Controller (DDC)

DDC is Real Time Control System for testing Engines on Engine Dynamometer. DDC is also called digital dynamometer controller, In order to test the engine it is generally necessary to use a dynamometer controller. This is usually an electronic unit which has the capability of controlling the load on the dynamometer (i.e. it controls the current to the resistance coils in an eddy current dynamometer) and can measure or sense the load and speed [4]. Dynamometer controllers generally operate in two modes: Speed Controlled operation or Load Controlled operation. These two modes are controlled by PID & implement PID in DDC.

2.3 Speed Controlled Mode In DDC (N% Mode)

In Speed Controlled mode a set speed is given to the PID controller, if the measured speed of the shaft is less than that of the set speed, the load is decreased. If the measured speed of the shaft is greater than that of the set speed, then the load is increased. Assuming the engine has sufficient torque to attain the set speed; this will maintain a constant speed of engine which is under test [4]. Schematic of speed controlled test of IC engine is as shown in fig 3.0[4]. where throttle valve is 100% open to test speed parameter of engine, by varying load & keeping speed constant of ic engine. This is first control objective of this paper at N% mode. Where speed (N) is controlled by dynamometer controller acts as PID1 while % (throttle position) is controlled by throttle actuator acts as PID2.

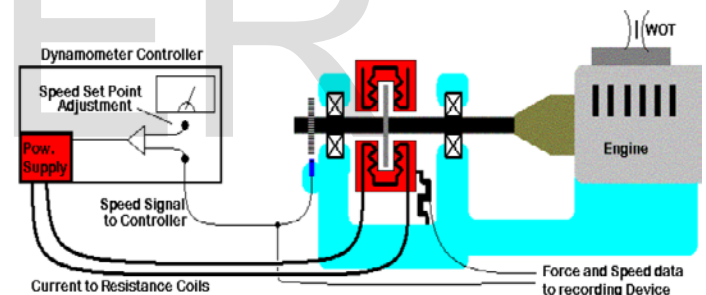

Fig 3: Schematic of speed controlled test at WOT or N% mode

2.4 Load Controlled Mode in DDC (T% mode)

In Load Controlled mode a set load is given to the controller (either as a voltage or a setting on the front panel of the controller). If the measured load on the dynamometer is greater than that of the set load, the load is decreased. If the measured load on the dynamometer is less than that of the set load, then the load is increased. Assuming the engine has sufficient torque to attain the set load; this will maintain a constant load while the speed varies [4].

3 ENGINE BEHAVIOUR

An Engine is a device which transforms chemical energy of fuel in to thermal energy & uses thermal energy to produce mechanical work. engine normally converts thermal energy in to mechanical work. There are three basic methods for measuring engine output: testing on an engine dynamometer, running a vehicle on a chassis dynamometer, or making passes at a race

track. This paper shows testing of engine using dynamometer. An engine dynamometer calculates power output directly by measuring the force (torque) required to hold a spinning engine at a set speed (rpm) means through engine behavior as shown in below table I here two quantities are under controlled such as torque & speed so two PID are required one (PID 1) for dynamometer where speed & torque has to be controlled & other PID 2 for throttle which is built in throttle actuator, so that two controlling modes are designed in DDC such as N% mode & T% mode as shown in table II.

Table I: Engine Behavior.

	Throttle Position									
	100 %	90 %	80 %	70 %	60 %	50 %	40 %	30 %	20 %	10 %
500	7	6.6	6.5	6	5.6	5.5	4.1	2.9	1.9	1.0
1000	8	8	5.9	5	4.1	3.3	2.6	1.9	1.3	0.8
1500	9	7.4	6.1	5.3	4.7	4	3.3	2.5	1.7	1.1
2000	10.5	8.7	7.9	7.1	6.4	5.6	4.8	4.1	3.4	2.1
2500	11.7	10.4	9.4	8.6	7.8	7.1	6.4	5.6	4.7	3.9
3000	12.1	12	11.1	10.3	9.5	8.6	7.8	6.9	6	4.5
3500	13.1	13.7	12.7	11.8	10.9	10	9.2	8.2	7.3	6.3
4000	14	15.1	14.2	13.3	12.4	11.4	10.5	9.5	8.4	7.2
4500	15.1	16.5	15.6	14.7	13.7	12.8	11.8	10.8	9.8	8.3
5000	16.1	17.9	16.9	16	15.1	14.1	13.1	12.7	11	10
5500	17	19.3	18.3	17.3	16.3	15.4	14.3	13.1	12	10.5
6000	18.4	20.1	19.3	18.5	17.5	16.4	15.4	14.2	13	11.6

Speed

Torque

Table II: Controlling Mode in DDC.

Sr. No	Controlling Mode in DDC	Engine Parameter Controlled By Dynamometer (PID1)	Engine Parameter Controlled By Throttle (PID2)
1	N% Mode	Speed	Throttle
2	T% Mode	Torque	Throttle

4 CLOSED LOOP DIAGRAM FOR N% & T% MODE:

The engine is the most important part of the process plant as this is where the process variables are measured and controlled. Figure 4 shows the closed loop speed/torque control diagram of the engine with dynamometer. In closed loop diagram set speed or torque are given to PID, final control element is load cell when PID 1 is running while throttle valve acts as second final control element when PID2 running, engine acts as process whose two variables such as speed & torque are under measurement. Dynamometer acts as measuring device in which speed & torque sensors are located, from these sensors engine feedback speed & torque are measured. Finally tune PID to achieve set variable & process variable of engine becomes equal. PID output range is required from 0 to 10v, speed range of engine under test is from 500 to 6000rpm while torque range of 5 to 20 N-M at weight of 5 to 20 kg

weight on load cell.

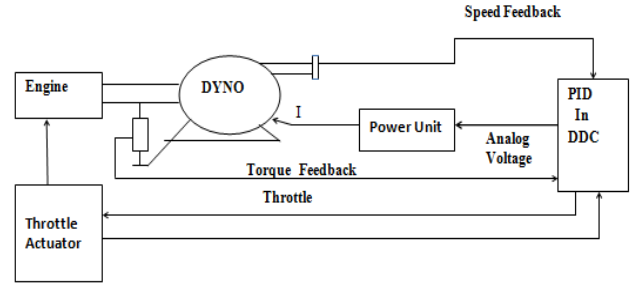

Fig 4: Closed loop Speed (N%) & Torque (T%) Control diagram.

5 GENERAL STEPS FOR PID DESIGN

- Obtain open loop response, add K_p to reduce rise time, K_i to eliminate steady state error, K_d to increase stability of system, improve transient response & improve overshoot.
- Model estimation.
- Controller tuning.
- Set point change test (closed loop).
- Verify.

A designing of PID controller main aim is to minimize error between process variable & setpoint while generating corrective action to control system. A conventional PID controller consists of a Proportional element, an Integral element and a Derivative element. All of them take the error as input. K_p , K_i , K_d are the gains of P, I and D elements respectively shown in equation (2). [3, 9]. Where e is error signal, K_c is controller gain, τ_i is integration time, and τ_d is derivative time. A PID controller determines a controller output value $u(t)$, engine under test [7].

General control equation of PID:

$$u(t) = K_c \left\{ e + \frac{1}{\tau_i} \int_0^t e dt + T_d \frac{de}{dt} \right\} \quad (2)$$

So PID values can be calculated using equation (3) as below.

$$P = K_c, I = \frac{K_c}{\tau_i}, D = K_c \times T_d \quad (3)$$

5.1 Open Loop Test

Generally, most PID tuning methods are based on the assumption that the plant can be approximated using first order plus dead time model (FOPDT) which is mathematically described by equation (4)[1]. The process parameters such as the gain k , the dead time, θ and time constant, T appeared in equation (4) can be determined by performing an open loop or some dynamic test on the actual plant. The simplest test that can be performed is the step test [1]. By using identification tool and open loop response of the plant, we can get transfer function for the plant shown in next section [10]

$$G_p(s) = \frac{K e^{-\theta s}}{T s + 1} \quad (4)$$

5.2 Engine Model Estimation

I have developed process parameters for the engine process as $K = 325.11$, $\theta=3.6835$, $\tau = 1.0962$ for N% mode in addition to that $K = 1.0741$, $\theta=0.002$, $\tau = 0.275$ for T% mode. These values are found using engine FOPDT model of engine. (using input-output values of engine). The Engine FOPDT model is developed by engine behavior in which speed (RPM) vs torque (NM) with respect to throttle position (%) means acts as engine data is shown in fig 4.0, engine FOPDT mathematical equation for N% mode for engine is given by

$$G_p(s) = \frac{325.11}{1.0962s+1} e^{-3.683s} \quad (5)$$

Equation (5) shows transfer function of engine under test for N% mode. This transfer function developed by engine data where input of engine is load varies from 5 to 20 N-M while output of engine is speed varies from 500 to 6000rpm at constant throttle position 100%.

Engine FOPDT mathematical equation for T% mode for engine developed using engine behavior where input of engine is load & output of engine is torque varies from 5 to 20 N-M at constant throttle position at 50% which is given by equation (6):

$$G_p(s) = \frac{1.0741 e^{-0.002s}}{0.2755s+1} \quad (6)$$

5.3 Controller Tuning

Tuning of control loop is the adjustment of its control parameter to the optimum values. They ensure that the resultant process control system would be stable and would achieve the desired objectives. Tuning methods of controller describe the controller parameters in the form of formulae or algorithms. In literature, a wide variety of PID controller tuning methods are proposed. These are broadly classified into three categories such as closed loop method, open loop method & soft computing method out of these methods Ziegler Nichols closed loop tuning method is used in this work

Transfer function of the most basic form of PID controller is by equation (7) [6].

$$G_c(s) = P + I/s + Ds = K_c (1 + 1/T_i S + T_d S) \quad (7)$$

Where $P = K_c$, $I = K_c/T_i$ and $D = K_c T_d$ are tuning parameters of the PID controller.

In general, a wide variety of PID controller tuning methods are used such as open loop method, closed loop method, soft computing method [6]. This paper presents a simulation study on PID controller tuning for engine with dynamometer process using well-known Z-N closed loop method. In closed loop tuning methods the plant is operating in closed loop and controller tuning is performed during automatic state. Ziegler-Nichols (ZN) tuning rule was the first tuning rule to provide a practical approach for PID controller tuning. Based on the rule, a PID controller is tuned by firstly setting it to the Proportional-only mode but varying the gain to make the process system in continuous oscillation. The corresponding

gain is called as the ultimate gain K_u and the oscillation period is denoted as the ultimate period P_u . A Simulink model using LabVIEW for closed loop process with P-control is simulated to determine the above parameters. The ultimate gain K_u and the ultimate period P_u are also calculated analytically using Routh array. Then, the controller tuning parameters (P,I,D) are calculated from K_u and P_u using the Ziegler-Nichols tuning Table III [6].

Table III: Z-N closed loop tuning using oscillation method

Control	P	T _i	T _d
P	$K_u/2$	-	-
PI	$K_u/2.2$	$P_u/1.2$	-
PID	$K_u/1.7$	$P_u/2$	$P_u/8$

5.4 PID Values for Engine Model

Using Z-N closed loop tuning method as described above I have developed PID values for N% & T% mode are shown in table IV.

Table IV: Z-N closed loop tuning using oscillation method for N% & T% mode.

Tuning method	PID Value for N% MODE		
	P	I	D
Z-N	0.002	0.00506	0
Tuning method	PID Value for T % MODE		
	P	I	D
Z-N	2.22	12.79	0

6 EXPERIMENTAL WORK

The experimental work was conducted by first performing the open-loop test to the engine plant in order to determine the above mentioned process parameters. Based on these parameters, the process model is identified and the controller is tuned [1]. In experimental work first PID controller was developed for N% & T% mode in DDC using flowchart as shown in fig 5.

The results were plotted and are discussed in the next section.

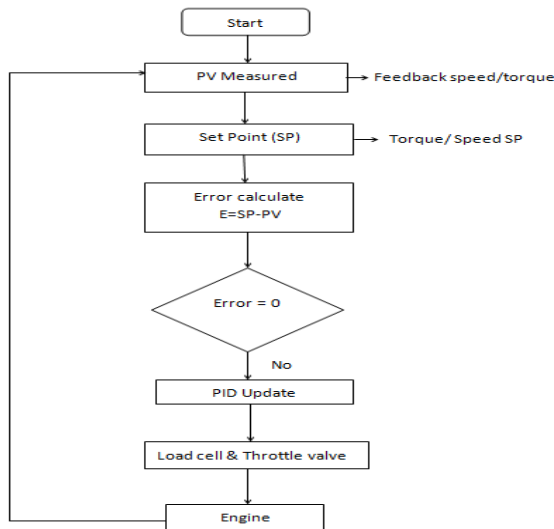

Fig 5: Flowchart of PID design for N% & T% mode in DDC.

7 SIMULATION RESULTS

Simulation is a process that involves using software to recreate and analyze the behavior of dynamic systems means here to analyze engine behavior. A dynamic system model is a differential equation that describes the behavior of engine model. Labview software package was used for simulation work .In general LabVIEW (short for Laboratory Virtual Instrumentation Engineering Workbench) is a platform and development environment for a visual programming language from National Instruments. The graphical language is named "G". Originally released for the Apple Macintosh in 1986, LabVIEW is commonly used for data acquisition, instrument control, and industrial automation .LabVIEW programs/subroutines are called virtual instruments (VIs). Each VI has three components: a block diagram, a front panel, and a connector pane[5]. LabVIEW has several modules and Toolkits for Control and Simulation purposes, e.g., "LabVIEW Control Design and Simulation Module", "LabVIEW PID and Fuzzy Logic Toolkit" these toolkits are used in this simulation work[5,8]. This paper mainly contain two PID VI in DDC. The PID VI implement in labview has inputs for setpoint, process variable, PID gains, dt, output range, and reinitialize . In that PID gains input is a cluster of three value such as proportional gain, integral time, and derivative time calculated from engine transfer function form two controlling mode.,output rangein PID vi to specify the range of the controller output. The default range of the controller output is -100 to 100, which corresponds to values specified in terms of percentage of full scale & dt to specify the control-loop cycle time. The default value is -1, so by default the PID VI uses the operating system clock [7,10]. As per engine process parameter developed from FOPDT model , Output response of labview based PID tuning using Z-N for N% & T%mode are shown below, where control design & simulation loop contain PID , mathscript node is used to show transfer function of engine for two modes ,waveform chart to display setpoint & process variable of engine all these

tools are kept in while loop through labview in block diagram window of N% &T% Mode in fig 7 & fig 9,while front panel window of N% & T% Mode in fig 6 & fig 8 contain three numeric control such as K_p , K_i ,vertical pointer slide & one PID indicator with waveform chart. In labview control acts as input of plant while indicator acts as output of plant which are display in front panel.

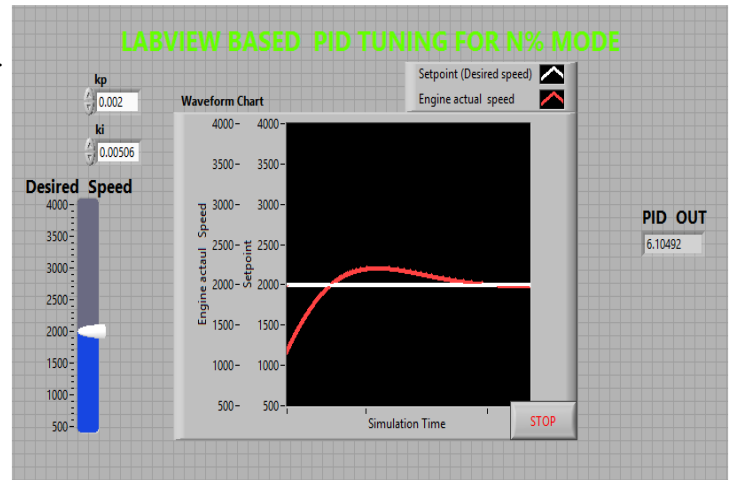

Fig 6: Front panel of Labview based PID tuning using Z-N method for N% mode

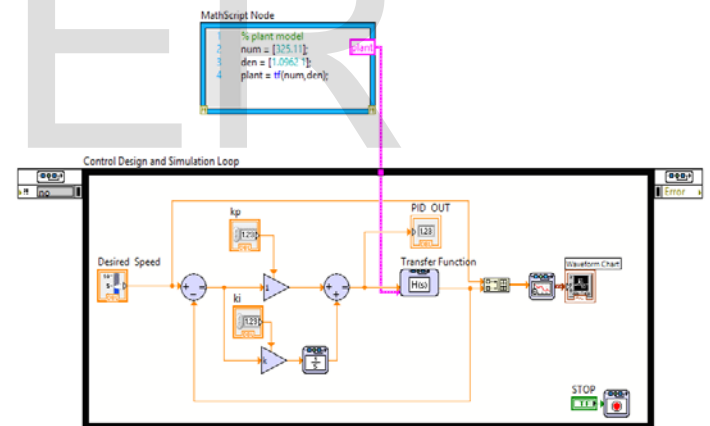

Fig 7: Block diagram of Labview based PID tuning using Z-N Method For N% mode.

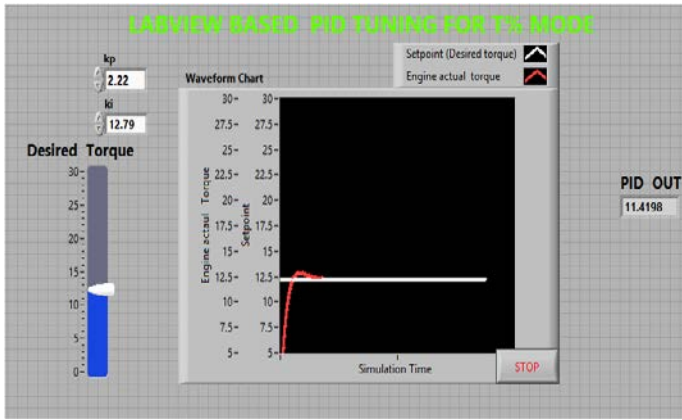

Fig 8: Front panel of labview based PID tuning using Z-N method for T% mode.

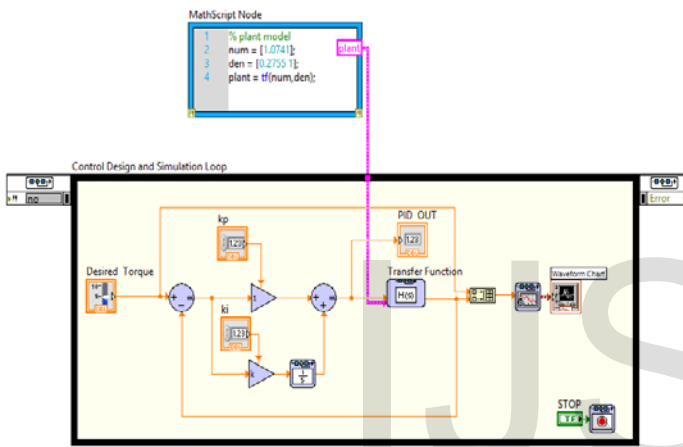

Fig 9: Block diagram window of Labview based PID tuning using Z-N for T% mode. Graphical user interface (GUI) for N% & T% mode using labview shown below graph in that two PID are located in DDC for simulation purpose.

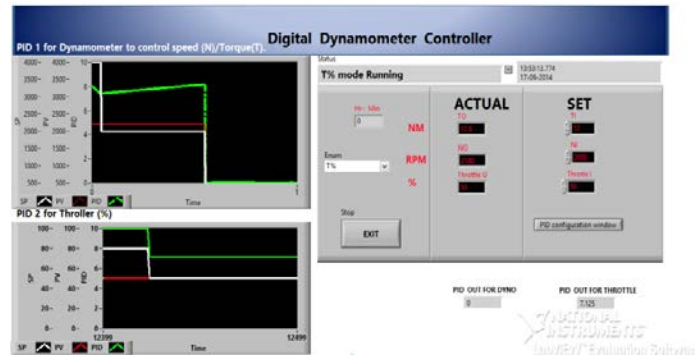

Fig 11: Front panel window of GUI for T% mode.

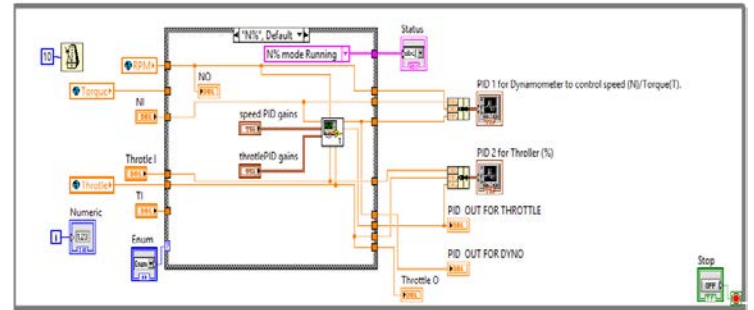

Fig 12: Block diagram window of GUI for N% & T% mode.

8 CONCLUSION

The PID controller tuning for engine with dynamometer was successfully simulated and tested. The results had shown that the Z-N tuning method was the best tuning method for engine testing & labview was best software tool to implement GUI also through simulation results i have concluded that, A GUI was developed to facilitate control-mode selection, the setting of controller parameters, and the display of control system variables through labview. finally in DDC simulation results are displayed shown in table V.

Table V: Simulation result for engine under test using setpoint change test For N% & T% mode in DDC.

Mode in DDC	setpoint speed	Actual engine speed (PV)	PID out	Throttle Position in %	Load value
N% Mode	2000	2180	8.036	100	10.5
	2500	2490	7.591	100	11.7
	3000	2850	6.39	100	12.1

Mode in DDC	setpoint Torque	Actual engine torque.(PV)	PID out	Throttle Position in %
T% Mode	12	12.8	0	50
	15	14.8	0.0276	50
	16	15.9	0.0402	50

Fig 10: Front panel window of GUI for N% mode

REFERENCES

- [1] N. Kamaruddin, Z. Janin, Z.Yusuf, M.N. Taib," PID Controller Tuning for Glycerin Bleaching Process Using Well-Known Tuning Formulas- A Simulation Study"IEEE, 2009
- [2] Dr. Gitano Horizon," Agilent Small Engine Dynamometer Testing Performing Dynamometer Testing on Combustion Engines", University Science Malaysia.
- [3] Ms. Reshmi P. Pillai, Sharad P. Jadhav ,Dr. Mukesh D. Patil, "Tuning of PID Controllers using Advanced Genetic Algorithm" International Conference & Workshop On Advance Computing 2013
- [4] Dynamometer Basics Dr. Horizon Gitano University Science Malaysia.
- [5] Anjali S. Ashtekar, Bhagsen J.Parvat, Chandrakant B. Kadu, "Application of MODBUS to Communicate the PLC and Labview for Real Time Process Control", (IJESE) , Volume-1, Issue-11, September 2013.
- [6] P.Srinivas, K.Vijaya Lakshmi, V.Naveen Kum," A Comparison of PID Controller Tuning Methods for Three Tank Level Process" International Journal of Advanced Research in Electrical, Electronics and Instrumentation Engineering Vol. 3, Issue 1, January 2014.
- [7] LABVIEW PID Control Toolkit User Manual from national instrument.
- [8] Pratap Vikhe, Neelam Punjabi, Chandrakant Kadu," Real Time DC Motor Speed Control using PID Controller in LabVIEW", ijareej, Vol. 3, Issue 9, September 2014.
- [9] C.B.Kadu, S.B.Bhusal, S.B Lukare," Autotuning of PID controller for robot arm & magnet levitation plant", IJRET, Volume: 04 Issue: 01, Jan 2015.
- [10] Hans petter halvorsen"Control and Simulation in LabVIEW tutorial", Telemark University College, Department of Electrical Engineering, Information Technology and Cybernetics.